



Precision Brewing,
Versatile Creation

JL37 SERIES

Commercial Fully Automatic Coffee Machine

CONTENTS

- Product Highlights
- Product Features
- Core Components
- Product Parameters
- Product Size
- Optional Parts
- Customization Details
- Clean Products
- Product Certificates
- Our Services



Product Highlights

Golden Extraction Quality

Dual-boiler system with a reheating boiler compensates for heat loss in the pipeline, ensuring optimal temperature stability for perfect coffee extraction.

Hot & Cold Milk Foam

Equipped with a professional milk pump and frother to create dense, silky milk foam for both hot and cold beverages.

Professional Steam Wand

Powerful and stable steam output allows simultaneous coffee extraction and milk steaming for efficient, café-grade performance.





Lockable Containers

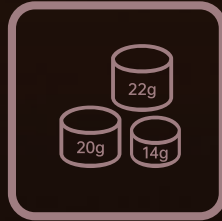

14g/ 20g/ 22g
ES Brewer



Hot/ Cold Milk Foam

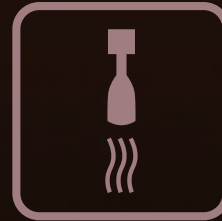

Separate
Hot Water Spout

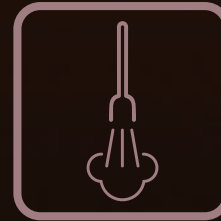

Separate Steam Wand

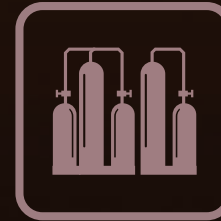

Dual Pumps
& Boilers



Water Tank



Syrup Station



ES Extraction

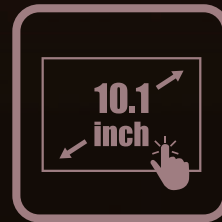

10.1 Inch Touchscreen



Automatic Cleaning



QR Code/
MDB Payment



Exceptional Quality Derives from Profession



Exceptional Quality Derives from Profession

PGH64 Grinder*1

(64mm flat burr, made of special steel)

ES Brewer

(P14, opt. P20/P22)

Waste Basket

(70 cakes, optional direct slagging off)

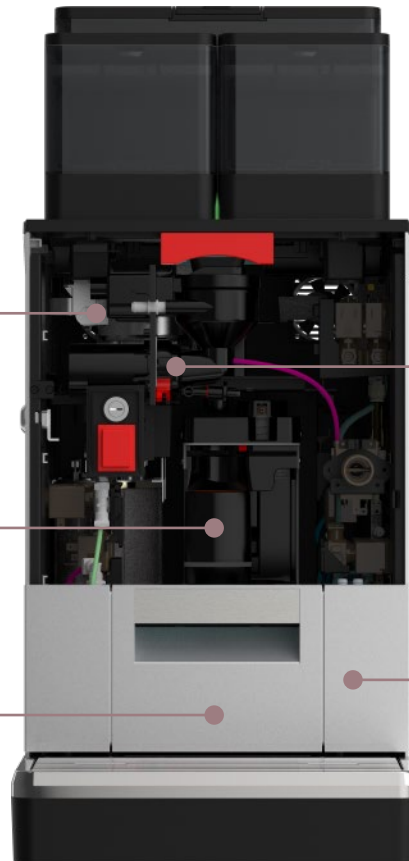

Mixer

Milk System



Fresh Milk System

With independent milk pump and foam generator, JL37 A/B models can easily produce delicate and smooth hot/cold fresh milk and milk foam.

A Variety of Coffee and Drinks

Dual grinding system on select models, together with instant powders and optional syrups, JL37 offers more beverage choices. Added with fresh milk system, it is able to make 30+ drinks.

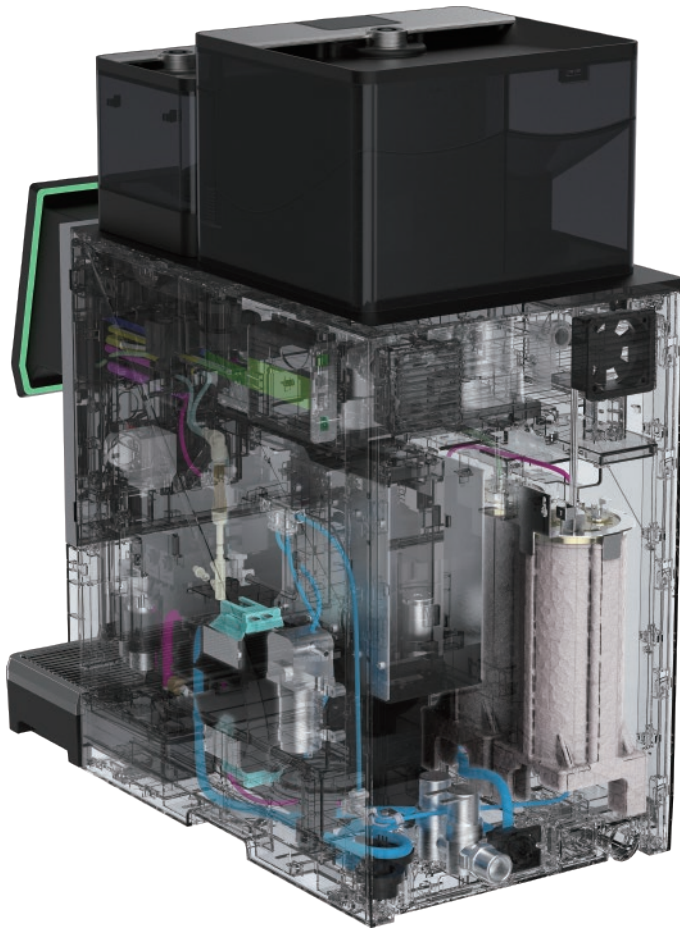

Double Boilers & Pumps

Dedicated pumps and boilers for coffee and steam enable simultaneous coffee brewing and milk frothing, boosting output speed and consistency.

4-Flavor Syrup Module

Enrich the beverages with more flavors.
(Optional, 4 bottles/pouches)

Details Make Professional



One Click Two Cups

Serve with 2 cups of coffee
at the same time.



Adjustable Spout

The height range is 80-180mm,
adjustable to fit with different cups.



Hot Water Spout & Steam Wand

Care more for cup warming
and manual coffee making.



Lockable Hopper & Canisters

See the bean and secure the
ingredients.

Exceptional Quality Derives from Profession



Start-up Cleaning

The machine will automatically make full machine cleaning every time it is powered on.



Timed Cleaning

schedule a time and the machine will conduct an auto full-machine cleaning.



Auto Milk System Cleaning

Upgraded self-cleaning with automatic tube closure prevents contamination—zero manual intervention.



Partial Cleaning

choose to separately clean key modules.



Deep Cleaning

use exclusive cleaners to deeply clean coffee and milk residue.



Manual Cleaning

Manually remove the module or parts and deeply clean by hand.

Jetinno SaaS Management

Support PC and mobile



Remote Control

Support remote control of recipes adjustment, machine setting, UI ads and video upload, machine system upgrade.

Malfunction Alert

Real time machine malfunction alert, can push notice to machine operator.

Comprehensive Data

Location deployment data, drink sale data, payment data, all these data statistics help operator better in machine operation and coffee vending business.

Powerful Machine Console Platform



- Drink Promo Tag Setting

- Drink Sale Report

- Ads Management

- Stock Management

- Drink Data Bank

Modular Design

The combination of modules has been fully considered in the design stage, and the beverage production modules such as coffee extraction module and instant module are flexibly combined into one machine to facilitate customers to put into different scenarios to meet user beverage needs.

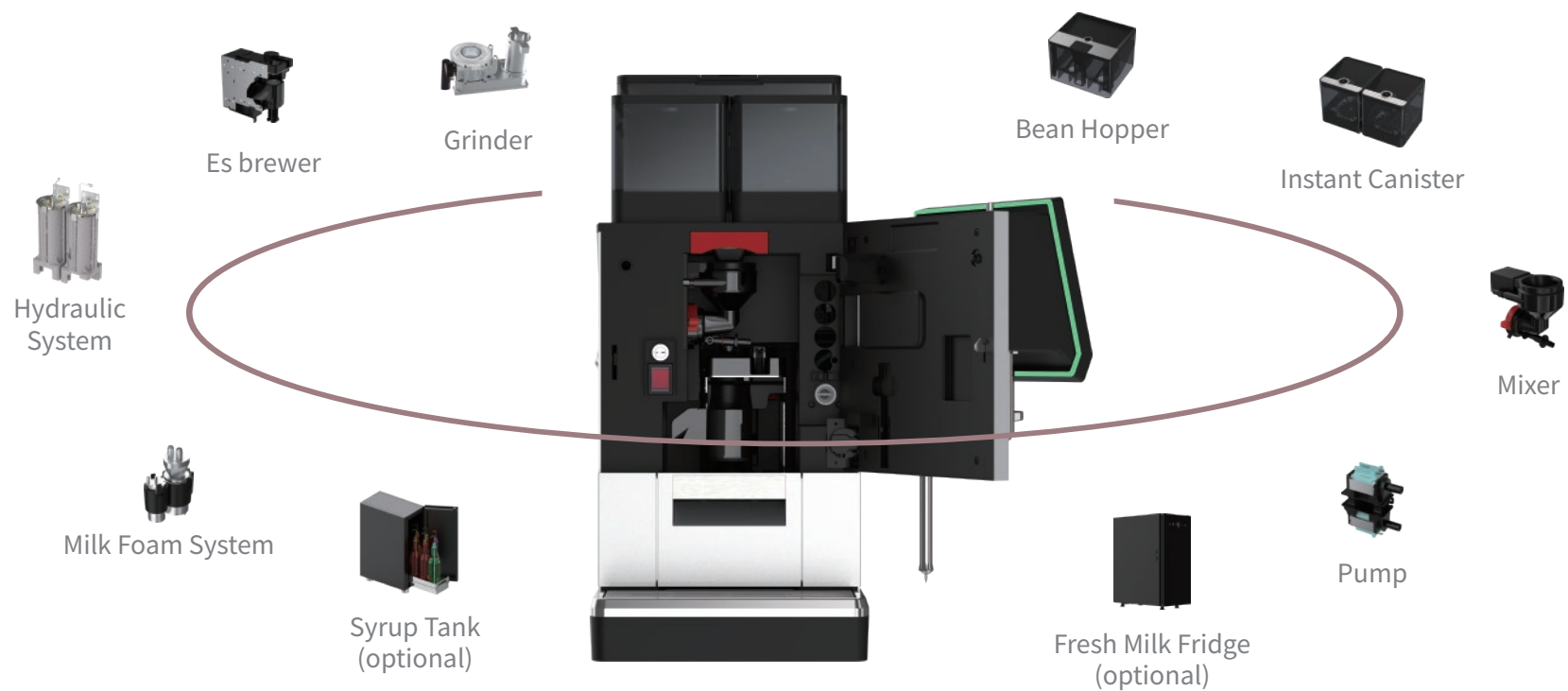

Jetinno Patented Hydraulic System & Boilers

- 700mL x2 large capacity stainless steel high-pressure boiler, with a maximum pressure resistance of 20bar
- 2700W heating power ensures continuous and stable outlet water temperature
- 3000W heating power ensures continuous and stable outlet steam temperature
- Independent modular design, convenient for disassembly and maintenance



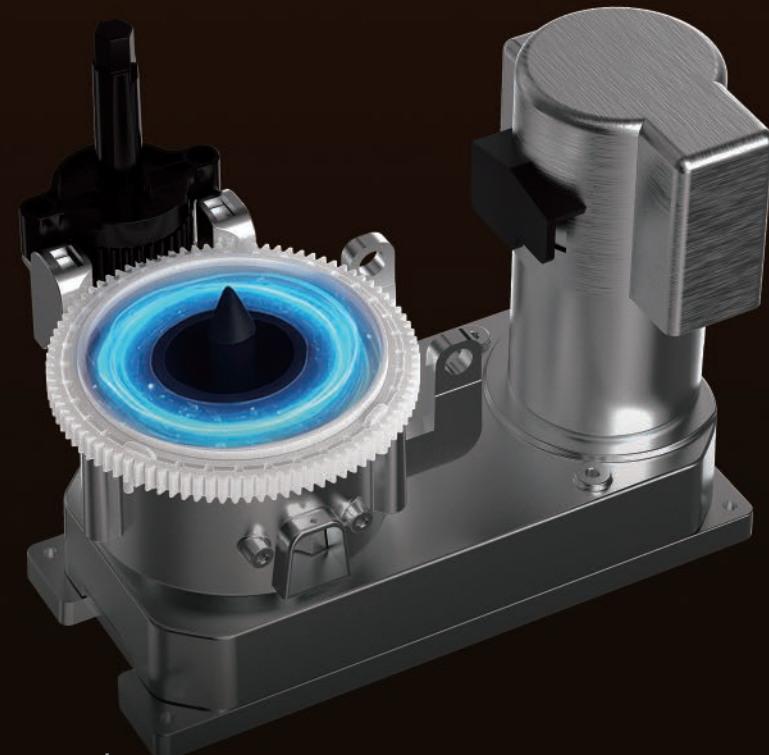

Jetinno grinder

- Patented tech innovated by Jetinno.
- European well-known grinding blade brand.
- 64mm Flat burr grinder, special made steel, high impact tolerance.
- Grinder lifetime: 62500 times(can grind approx 500kg coffee bean).
- Adjustable coffee ground fineness, easy to use.

Professional coffee brewing system

- Removable brewer module design, easy for cleaning.
- Jetinno PTC international patent, European time-honored brand applies the same type.
- Pre-infusion function to have saturated extraction.
- PTC heaters in brewing chambers, provide constant heating to solve low-temp of first cup.
- Built with 14g and optional 20g/22g brewing chambers, for different recipes.
- Detachable brewing chamber design, easy for deep-cleaning.
- Auto decompression function to discharge residual coffee liquid.

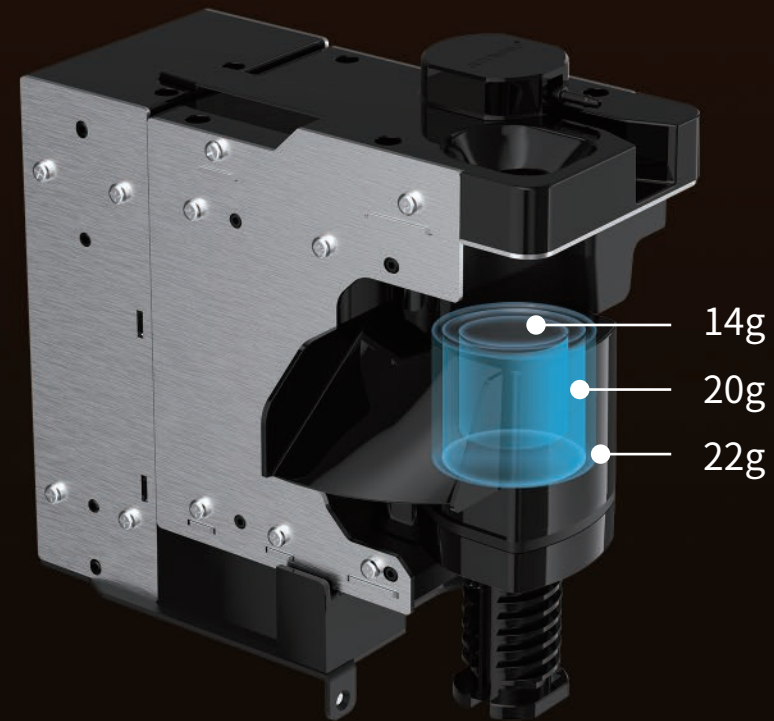

High speed stirring system

- Patented tech innovated by Jetinno.
- Detachable stirring chamber, easy for cleaning and maintenance.
- Up to 20000rpm stirring speed, rapid sufficient dissolution.
- Adjustable stirring speed for different recipes.
(milk foam requires high speed, instant coffee and tea drinks require low speed).



Jetinno Smart Milk Foam System

- Provide hot/cold Milk and hot/cold milk foam.
- Smart milk pump, makes dense and silky foam.
- Smart detection, milk tank empty alert.
- Milk system auto cleaning.









Multi-function main board

- Designed and developed by Jetinno.
- 8 core Cortex A7 CPU, 2GHz.
- Multiple network ports for network connection.
- Multiple displaying format ports and dual screen displaying.
- Up to 10-way ports expansion.
- Android system.

IO board

- Designed and developed by Jetinno.
- Quick response.
- Fast protection for malfunctioned unit.
- Precisely control all module units.
- Multiple ports expansion, can independently support 25-way control unit.
- Support various types of sensors, including temperature, humidity, flow and pressure.



Configuration	JL37A			JL37B		JL37C			JL37D	
	C1	C2	C3	C1		C1	C2	C3	C1	
	1700g	2L	2L	1700g		1700g	2L	2L	1700g	
	Bean 1	Topping (Cappuccino)	Topping (Cappuccino)	Bean 1		Bean 1	Topping (Cappuccino)	Topping (Cappuccino)	Bean 1	
										
		Milk pump Milk frother			Milk pump Milk frother					
Dimensions	312(W)*695(H)*608(D)mm									
Net Weight	36kg			33kg		34kg			31kg	
Power Supply	220-240V, 50/60Hz, 3100W			220-240V, 50/60Hz, 3100W		220-240V, 50/60Hz, 2800W			220-240V, 50/60Hz, 2800W	
Interface	10.1" Touchscreen									
Bean Hopper	1700g x 1, lockable									
Coffee Powder Bypass	Yes									
Instant Canister	2L x 2, lockable			-		2L x 2, lockable			-	
Syrup Station	Opt. 4 bottles/ pouches									
Grinder	PGH64 x 1									
ES Brewer	P22/P20/P14									
Milk System	Hot/ cold fresh milk & foam			Hot/ cold fresh milk & foam		-			-	
Hot Water Pump	2									
Boiler	2			2		1			1	
Beverage Spout Height	80-180mm									
Hot Water Spout	Yes									
Steam Wand	Yes									
Waste Basket	70 cakes, opt. direct slagging off									
Drip Tray	1.2L, opt. external drainage									
Water Supply	Barreled water/ tap water, opt. 8L built-in tank									
Internet Connection	Opt. Wi-Fi/ 4G									
Payment Method	Opt. QR code, MDB device									
IOT	Opt. SaaS Management									
Daily Output	200 Cups/Daily									

Top view

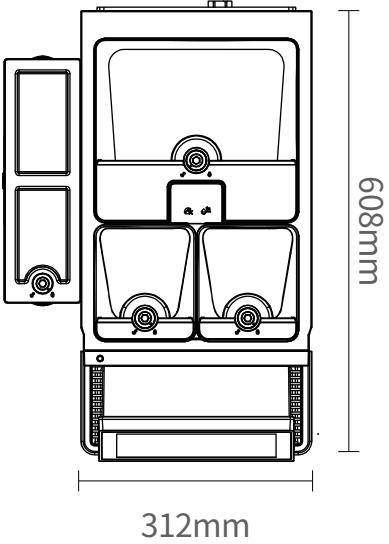

Front view

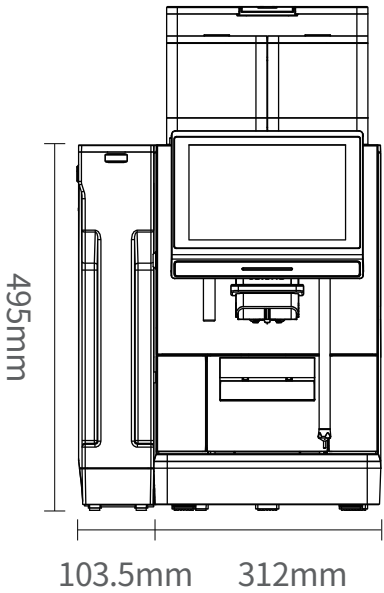

Side view

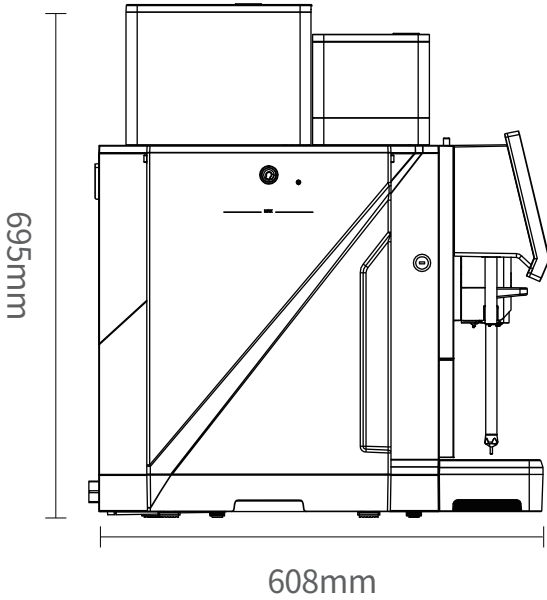

Package size: :554 (W) *732 (D) *786 (H) mm



Optional module	Optional or not
Waste Water Drainage	Optional
Slag off Waste Cakes	Optional
Fresh Milk Fridge	Optional
Syrup Module	Optional
4G card	Optional

Payment module	Optional or not
Facial scan payment	Optional
Reverse QR Code payment	Optional
Paper currency validator	Optional
Coin validator	Optional
RFID payment	Optional
MDB Cashless	Optional



JMC16 Milk Fridge

To keep fresh milk cool, prevent sour milk.

Item	Parameter
Voltage/Frequency	220-240V 50/60Hz
Power	60W
Temperature Range	0~4°C
Milk Box Capacity	2 x 4.5L
Effective Volume	16L
Packaging Dimension	315(W)*530(H)*665(D)mm
Outside Dimension	240(W)*450(H)*615(D)mm
Weight	16kg
Milk Position Alert	Yes

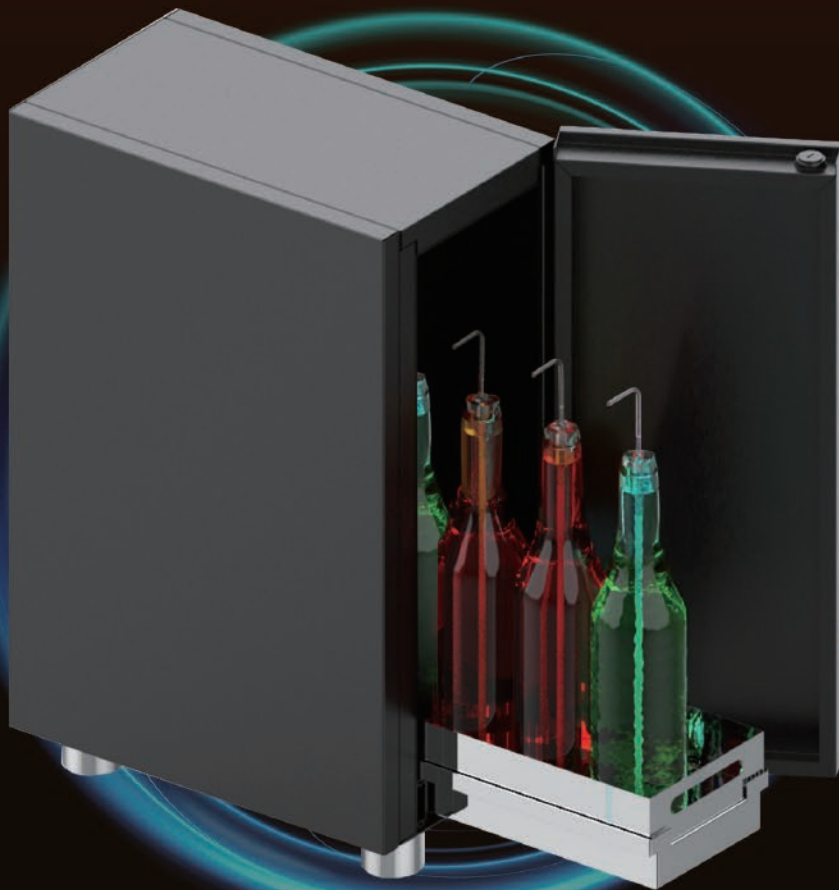

Syrup Module

More flavors of beverages, standardization of sweetness.

Item	Parameter
Module dimensions (W*H*D)	260x600x426mm
Weight	20kg
Syrup Group	4 bottles/pouches
Power supply	220-240V,50/60Hz
Rated power	<60W
Noise	W65dB(A)
Ambient Requirement	Temperature 5°C -35°C, Humidity 30-90%RH
Storing Temperature	0°C~+50°C
Storing Humidity	10%RH~90%RH

- Supports 4 different types of syrups
- Compatible with both bottled and bagged packaging

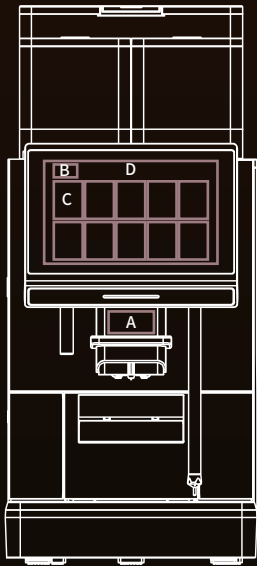

UI customization

Name	Position	Width	Height	Format
Brand LOGO	A	65.5mm	20mm	AI or cdr
UI LOGO	B	208PX	58PX	PNG
UI drink picture	C	300PX	300PX	PNG
Video ads	D	1280PX	800PX	PNG

Deep customization

Name	Item
Ports	Open underlying control serial port protocol, support customer self-developed APP.
	Open network interface(TCP/IP), support customer self-developed server.
	Open RESTful interface, support customer online store and data system.
OS	APP application layer customizable development (Android).



Product: coffee machine cleaner

Use: used for coffee machine brewer cleaning

Details: 2g/pill, 100 pills/can



Product: coffee machine boiler cleaner

Use: used for coffee machine boiler cleaning

Ratio: 200g powder with 3.9L water

Details: 1kg/bottle, 6 bottles/case



Product: towel

Use: used for coffee machine cleaning
and maintenance

Details : general use



Product: cleaning brush

Use: used for coffee machine cleaning
and maintenance

Details : general use



Security Certification



Food Contact Material

EU 1935/2004
European food test

Europe

LFGB
German



US

GB
GB4806
China

Europe EVA energy consumption level A

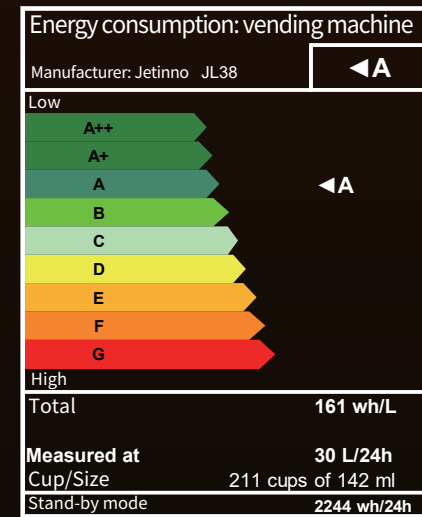

95% Recycled

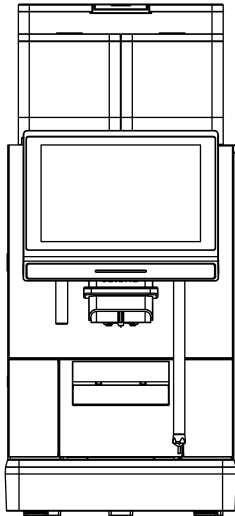

Guangzhou Jetinno Intelligent Equipment Co., Ltd

Address: No. 220, Xiangli Road, Huangpu District, Guangzhou, China

Tel: 400-017-9997

E-mail: inquiry@jetinno.com

Website: www.jetinnomachine.com | www.jetinnovending.com