

JETINNO®



**Your Ideal Fresh Milk
Coffee Maker**

JL30 Series

Commercial fresh milk coffee machine

CONTENTS

- Product Highlights
- Product Features
- Core Components
- Product Parameters
- Product Size
- Optional Parts
- Customization Details
- Clean Products
- Product Certificates



Upgraded, Excellence

Professional grinding system

Equipped with imported 64mm commercial-grade special steel flat burr, stable and durable; 11-level grinding adjustment for uniform and fine coffee grounds.

Ease maintenance

Multiple intelligent cleaning functions, including one-touch auto-cleaning and scheduled auto-cleaning; brewer designed for quick disassembly; smart bean detection.

Selectable brewer capacities

Designed to be compatible with both JETINNO S14 and S20 coffee brewers with different capacity specifications, considering various customer usage scenarios and coffee recipe requirements.





Steel flat burr



Fresh milk frothing



Espresso brewing



Detachable brewer



Auto cleaning



Bean detection



Large capacity

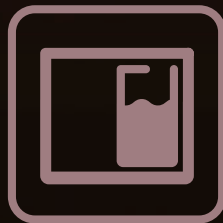

Selectable water tank



Single/dual cup



10+Drinks



45s fast production



Remote control



More Than Classic

4L fresh milk refrigerator
(temp. 1-6°C, optional module)



1.2kg bean hopper

7" touch screen

2L/8L water tank options

Height Adjustable Spout
(80-120mm)

1L drip tray
(full water detection,
optional waste water drainage)

Ingeniously Exceptional Design

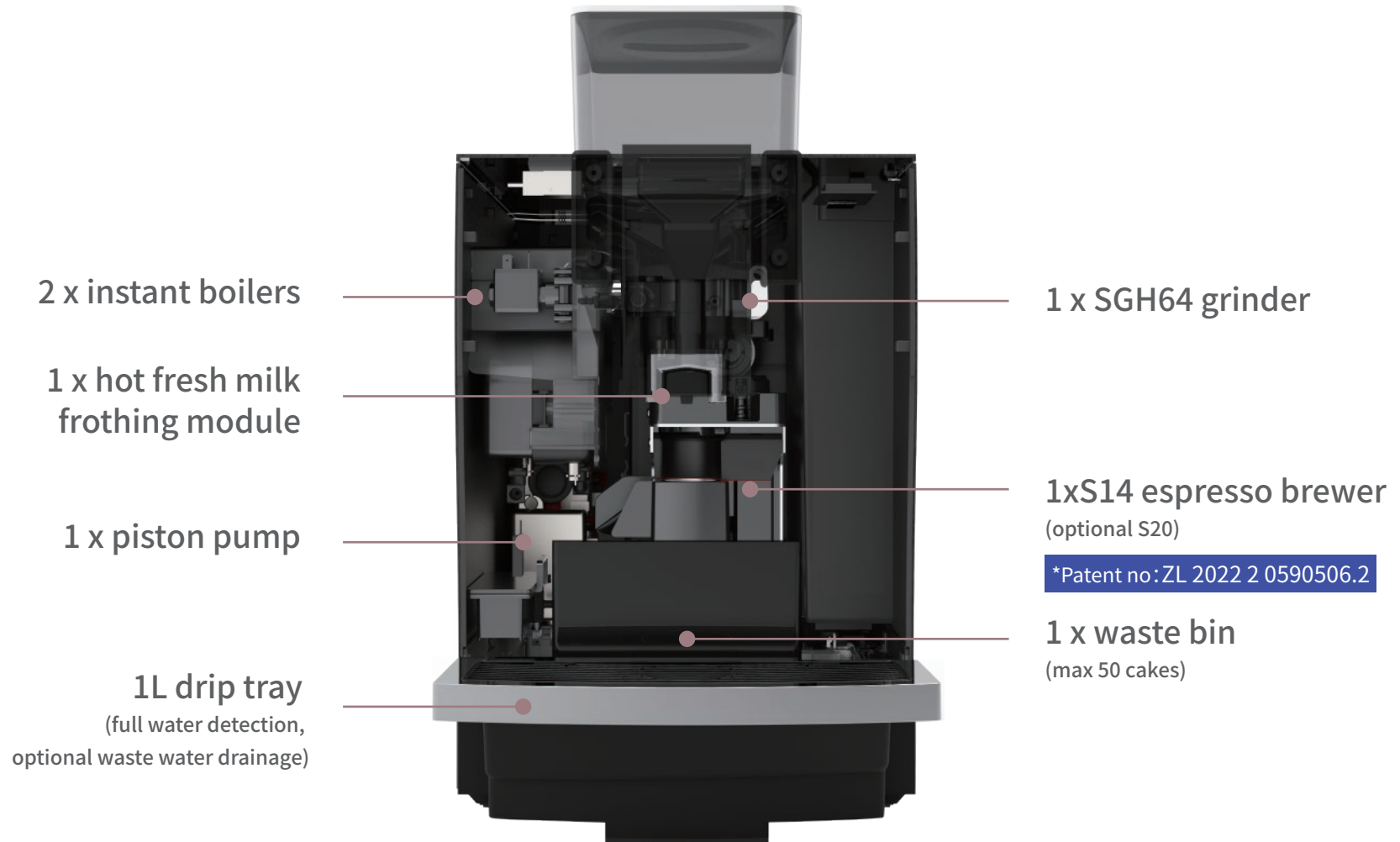



Special steel flat grinding burrs

64mm professional-grade imported steel burrs for impact resistance and quick heat dissipation, preserving coffee flavor.

Professional milk frothing system

With a dual boiler design for hot water and steam, it rapidly creates silky and dense milk froth, enhancing the creamy texture of milk-based coffee beverages.

Reliable components

With instant boilers, piston pumps, and commercial grade valves, ensuring excellent stability and prolonged lifespan.

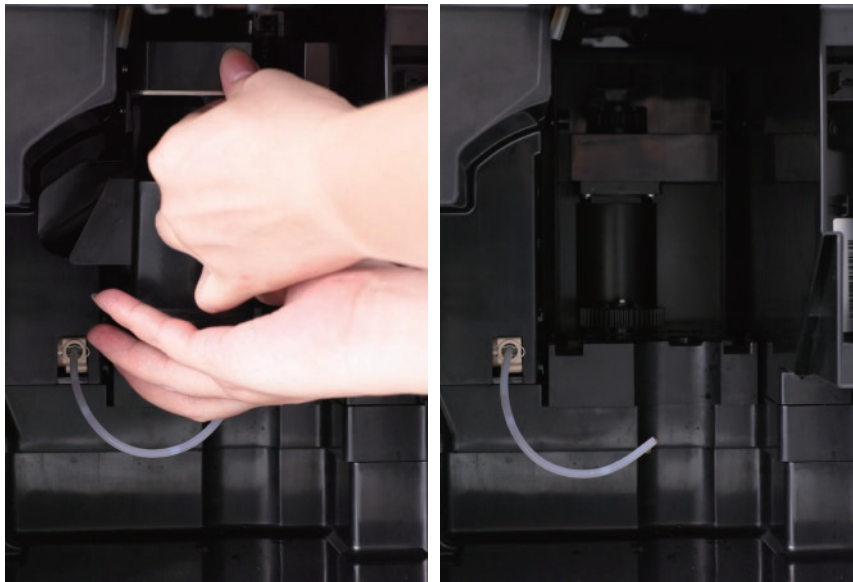
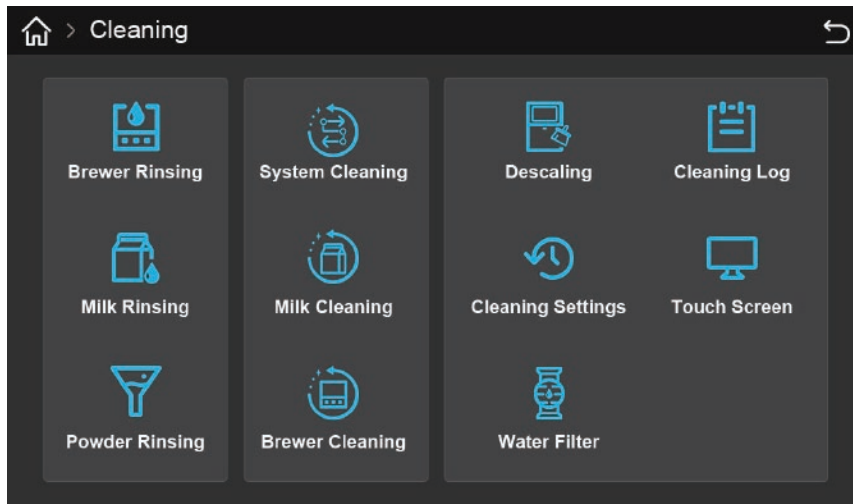

Snap-on design brewer

The coffee brewer can be quickly disassembled from the front for deep cleaning, preventing coffee oils from clogging the filter and affecting the coffee extraction.

14g/20g espresso brewer

The coffee brewer offers two options for brewing chamber capacity, with 14g and 20g specifications, meeting different scenarios' requirements for varying coffee ground weights.

Pre-infusion

Allows for a controlled wetting of the coffee grounds before extraction. This helps to enhance the flavor extraction process and ensure a well-balanced and flavorful cup of coffee.





Daily Output: **100** Cups/Daily

Drinks Outpt(based on protocol DIN18873-2 hourly output)

Espresso:90 American:65

Hot water:120

JL29A

Commercial espresso maker

Patent Brewing Technology

With a patented brewer, high-pressure brewing chamber, anti-gravity extraction, always enjoys the richness of coffee oils.

11 grinding size

Selected 64mm imported special metal grinding flat burr, fresh coffee powder coarseness stable and consistent.

Detachable design for easy cleaning

Detachable water drip tray, brewer snap-on design, can be quickly removed, easy to clean.



Daily Output: 100 Cups/Daily

Drinks Outpt(based on protocol DIN18873-2 hourly output)

Espresso:90 American:65

Hot water:120

JL29B

Commercial espresso coffee machine

Freshly Ground Black Coffee

Patented brewer optional 14/20 grams, with 64mm metal grinding flat burr, easily meet the different coffee flavour requirements.

7-inch vertical screen design

Up and down screen menu design, friendly customer interface and operator interface, the operation is more convenient and smooth.

One click dual cups

All beverages feature a one-touch dual-cup function, one time waiting, two times enjoy.



Daily Output: 100 Cups/Daily

Drinks Outpt(based on protocol DIN18873-2 hourly output)

Espresso:90	American:65
Cappuccino:65	Hot water:120

JL30

Commercial fresh milk coffee machine

Freshly extracted smooth taste

Freshly ground coffee beans, perfect extraction, this machine allows you to enjoy over 15 varieties of black and milk coffee beverages.

Dual-system efficient cleaning

Intelligent backend, capable of setting up automatic cleaning for all pipelines upon startup, scheduled cleaning, timed cleaning, one-touch cleaning.

Remote machine management

Real-time machine status, consolidated sales order records, intelligent reminders for bean and water shortages.



Daily Output: **100** Cups/Daily

Drinks Output(based on protocol DIN18873-2 hourly output)

Espresso:90	American:65
Cappuccino:90	Hot water:120

JL31A

Commercial efficient fresh milk coffee machine

One-touch Milk Coffee

With a dual-pump, dual-boiler design, it can simultaneously produce coffee and frothed fresh milk, enabling rapid cup delivery and effortlessly handling high demand during peak periods.

Details Design

Equipped with an independent hot water wand, adjustable water spout height from 80 to 160mm, 11-level adjustable grind fineness, detachable drip tray for easy cleaning.

Multiple Water Supply

Comes with a standard 8L built-in water tank and the option for bucket water supply, city water, allowing for easy switching.



Daily Output: 100 Cups/Daily

Drinks Outpt(based on protocol DIN18873-2 hourly output)

Espresso:90	American:65
Cappuccino:90	Hot water:120

JL31B

Commercial 10” screen fresh milk coffee machine

One-Touch Milk Coffee

Featuring a dual-pump, dual-boiler design, it can cater to the simultaneous production of coffee and frothed fresh milk, ensuring swift cup delivery and effortless management of peak demand.





Large Screen

Designed with a 10-inch large screen that seamlessly integrates with the elegant exterior design, further accentuating its high-end quality.

Detachable Brew Unit

The patented brew unit with a snap-on design, making it easy to remove and install. You can detach the brew unit in few seconds for convenient cleaning whenever needed.

*Materials marked for canisters above are customizable

Configuration	JL29A-ES1C	JL29B-ES1C	JL30-ES1C-FV	JL31A-ES1C-FV	JL31B-ES1C-FV
	<small>C1 1200g</small> Bean 	<small>C1 1200g</small> Bean 	<small>C1 1200g</small> Bean  <small>Venturi milk foam unit</small>	<small>C1 1200g</small> Bean  <small>Venturi milk foam unit</small>	<small>C1 1200g</small> Bean  <small>Venturi milk foam unit</small>
Model	JL29A	JL29B	JL30	JL31A	JL31B
Dimension	300*548*490mm	300*548*490mm	300*548*490mm	300*548*490mm	300*548*490mm
Net Weight	16kg	16kg	17kg	18kg	19kg
Voltage/Frequency	220-240V , 50/60Hz	220-240V , 50/60Hz	220-240V , 50/60Hz	220-240V , 50/60Hz	220-240V , 50/60Hz
Rated Power	1700W	1700W	1700W	2850W	2850W
Operation Interface	7" touch screen (horizontal)	7" touch screen (vertical screen)	7" touch screen (horizontal)	7" touch screen (vertical screen)	10" touch screen (horizontal)
Bean Hopper	1200g x 1	1200g x 1	1200g x 1	1200g x 1	1200g x 1
Grinder	Jetinno SGH64 x 1	Jetinno SGH64 x 1	Jetinno SGH64 x 1	Jetinno SGH64 x 1	Jetinno SGH64 x 1
Espresso Brewer	S14/S20 (optional)	S14/S20 (optional)	S14/S20 (optional)	S14/S20 (optional)	S14/S20 (optional)
Hot Water Boiler	1500W x 1	1500W x 1	1500W x 1	1500W x 1	1500W x 1
Steam Boiler	X	X	1300W x 1	1300W x 1	1300W x 1
Water Pump Type	piston pump x 1	piston pump x 1	piston pump x 1	piston pump x 2	piston pump x 2
Spout Height	80-160mm	80-160mm	80-160mm	80-160mm	80-160mm
Fresh Milk Refrigerator	X	X	Optional, 4L	Optional, 4L	Optional, 4L
Hot Water Spout	X	X	X	1	1
Waste Bin	50 waste cakes(10g), direct slagging off (optional)				
Drip Tray	1.0L, direct drainage (optional)				
Water Supply	2L (8L) water tank, barrelled water and mains water (optional)				
Internet	Optional Wifi or 4G				
Payment	Optional, MDB Protocol Payment / QR Code Payment				
Operating System	Android				
IOT	Optional				

Intimate Design, Delicious Coffee



One-touch dual-cup

One-touch for black coffee and milk coffee, enjoy a double delight.

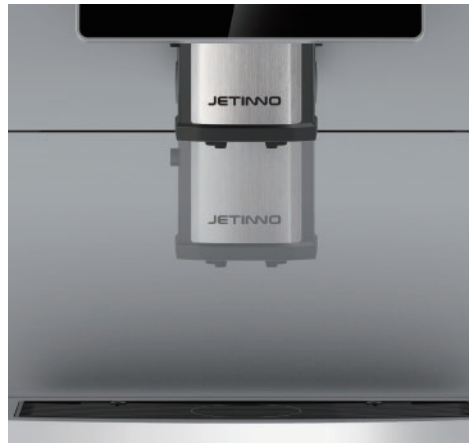

Adjustable spout height

Height range 80-160mm, accommodating various cup sizes.

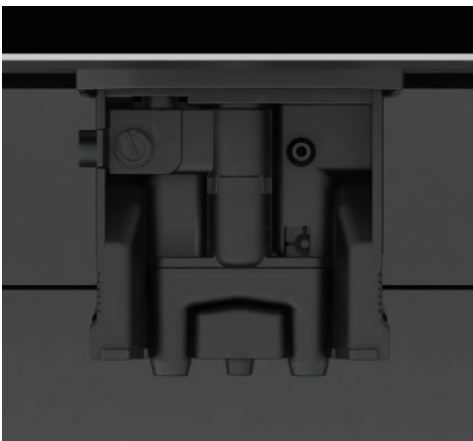

Detachable milk frothing module

Easy for deep cleaning, preventing hygiene issues.



Fits large and small tanks

Offering 8L/2L water tanks options to suit various scenarios.

Smart and Swift Cleaning

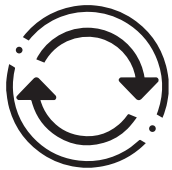

Self-detective

Automatically initiates comprehensive cleaning, covering all components and milk tubes for a thorough 360° cleaning.



Scheduled cleaning

Set cleaning intervals for automatic whole machine cleaning, offering smart and worry-free maintenance.



Automatic milk path cleaning

Timed automatic cleaning of the milk path to prevent milk residue and bacteria buildup.



Individual component cleaning

One-click cleaning for specific brewing components, reducing cleaning time and water usage.



Deep tablet cleaning

Supports manual tablet usage and automatic descaling function, ensuring comprehensive and thorough machine cleaning.



Deep cleaning

Brewing components' pipelines can be manually disassembled for thorough water washing, minimizing hidden residues.

Modular Design

During the design phase of the JL30 series, full consideration was given to modular combination design, allowing customers to choose a suitable coffee machine configuration based on different application scenarios and beverage demands.

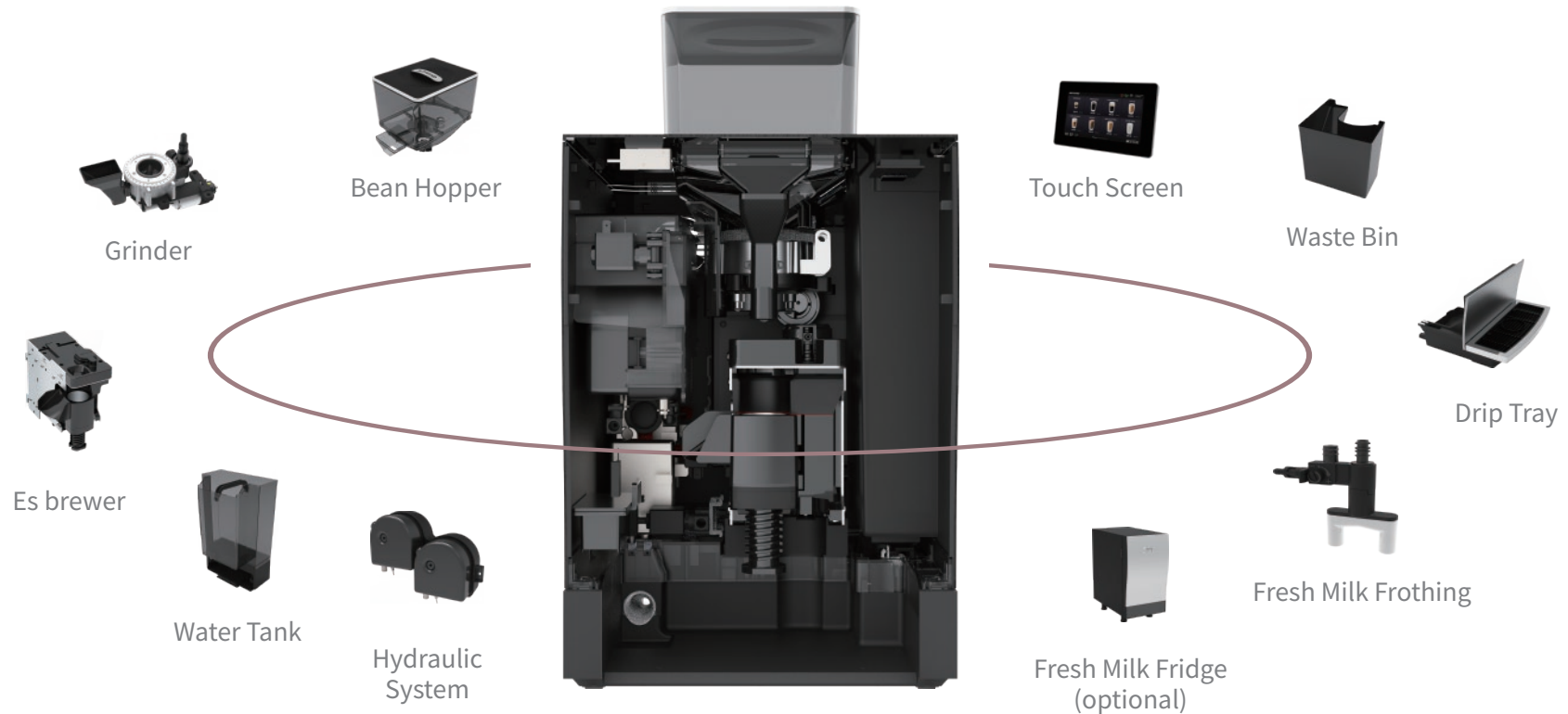

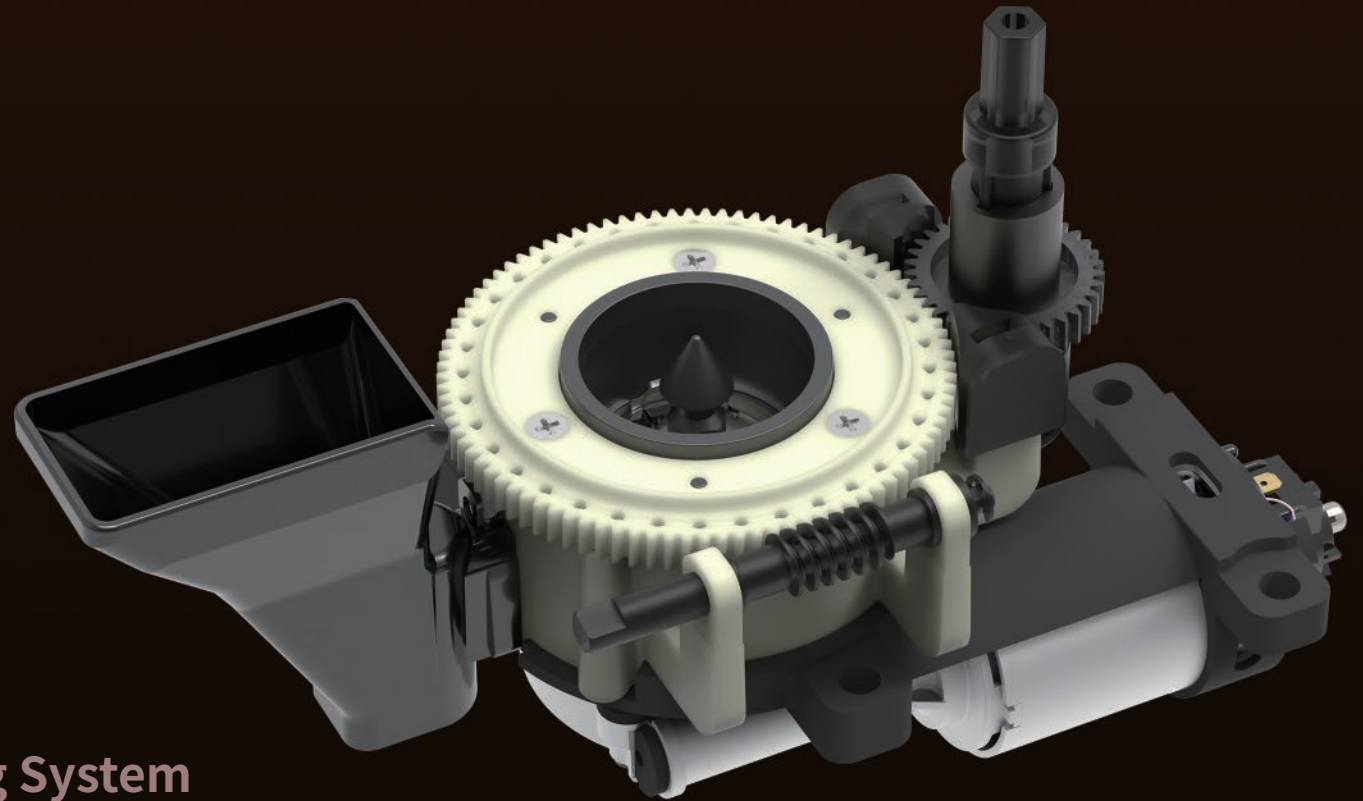

Jetinno SGH64 Grinding System

- 64mm special steel flat grinding burrs.
- Dissipate heat quickly, preventing coffee grounds from being reheated.
- 11-level adjustable grinding coarseness.
- 500kg coffee bean burr lifespan.

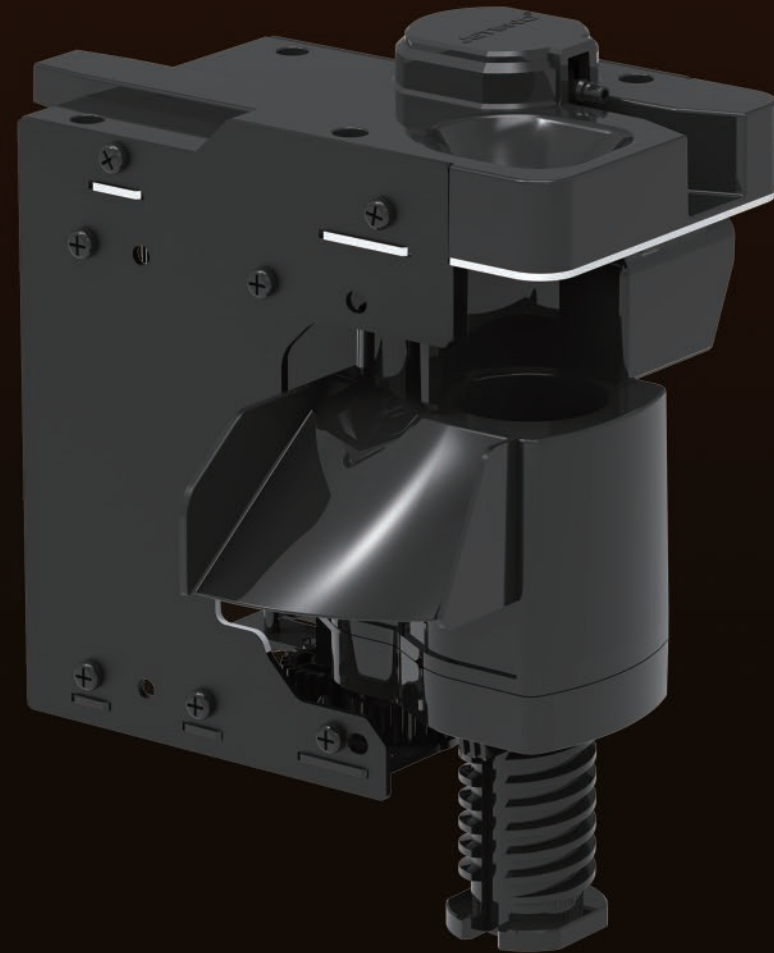

Jetinno High-Pressure Espresso Brewing System

- Pre-infusion extraction technology.
- Different locations for coffee bean loading and brewing.
- Optional 14g/20g brewing chamber capacity.
- Easy one-step disassembly for brewing.

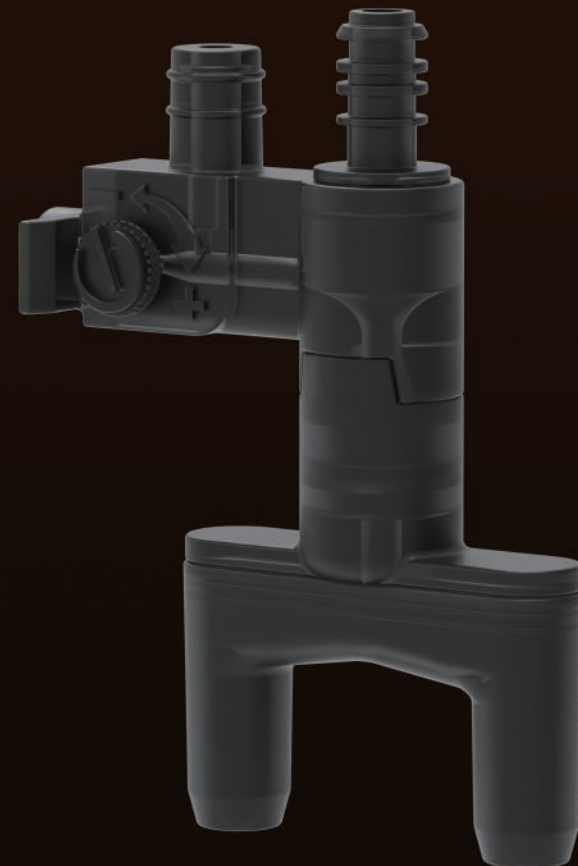

Hot Milk Frothing System

- Produces hot milk/foamed milk with a temperature of 60°C or above.
- Independently adjusts the froth volume in the beverage.
- Timed automatic cleaning of the milk path.
- Snap-on design allows for quick disassembly.



Hydraulic System

- Dual instant boilers provide 92°C hot water.
- Italian ARS high -pressure electromagnetic pump, provides strong and stable extraction pressure.
- Solenoid valves with a long lifespan.
- Independent modular design.

Front view

Side view

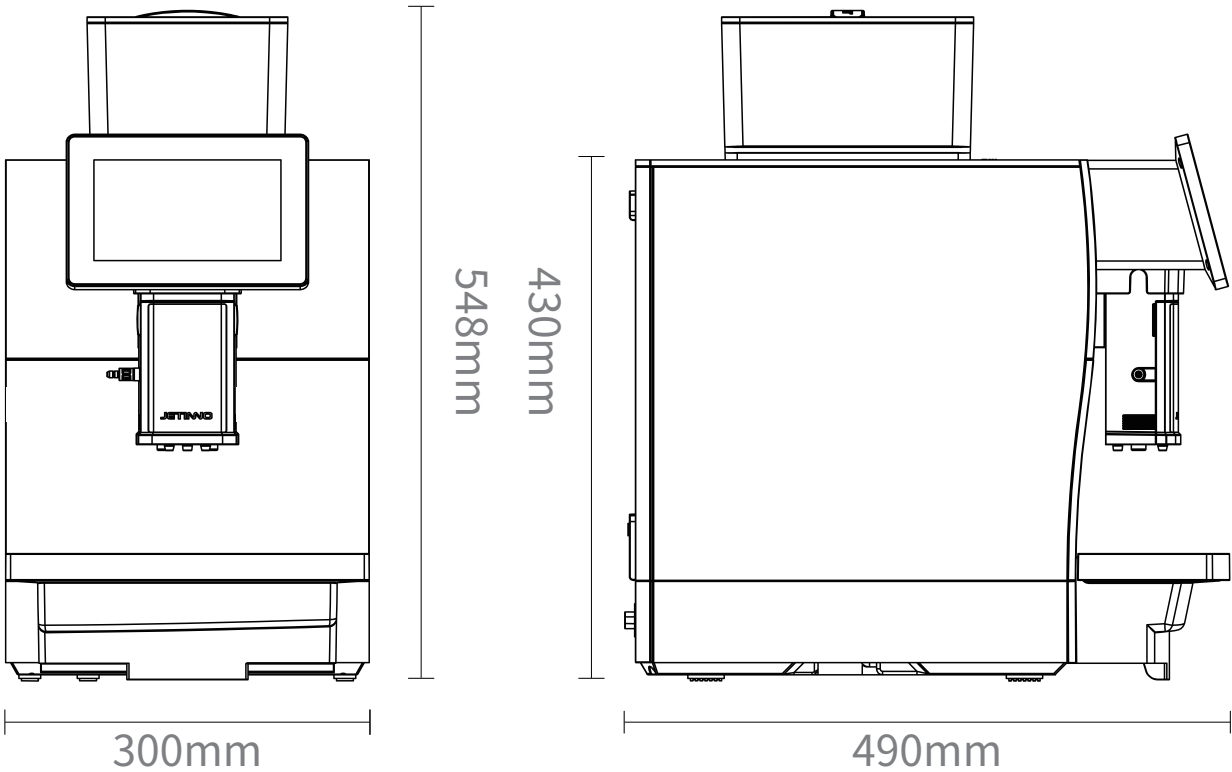

Package size: :615 (W) *515 (D) *630 (H) mm



Configuration Module	Optional
Waste water discharge	Yes
Fresh Milk Refrigerator	Yes
Router	Yes
4G sim card	Yes

Payment Module	Optional
Reverse QR Code Payment	Optional
Cash Note Acceptor	Optional
Coin Dispenser	Optional
MDB Cashless	Optional



Fresh Milk Fridge

To keep fresh milk cool, prevent sour milk.

Item	Parameter
Size	220 (w) *400 (h) *400 (d) mm
Rated Power	220-240V, 50/60Hz, 0.45A, 70W
Energy Efficiency Rating	Class A
Safety Rating	GB/T 9237-2017 or GB/4706.1-2008
Power consumption (standby)	≤0.4kw.h/24h (25°C ambient temperature)
Cooling time	≤30min
Cooling temperature	2-6°C
Milk box	4L
Refrigerant	R600a

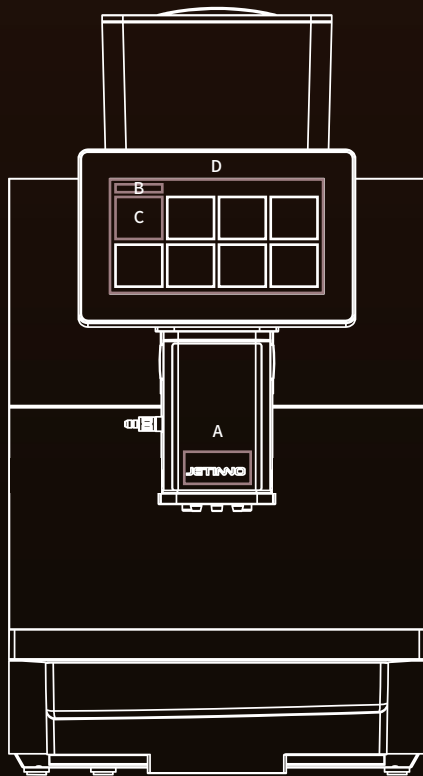

Customized UI

Name	Position	Width	Height	Format
Brand LOGO	A	42.5mm	5.6mm	AI or cdr
UI LOGO	B	160PX	20PX	PNG
UI drink picture	C	224PX	229PX	PNG
Video ads	D	1024PX	600PX	MP4

Deep Customization

Name	Item
Ports	Open underlying control serial port protocol, support customer self-developed APP.
	Open network interface(TCP/IP), support customer self-developed server.
	Open RESTful interface, support customer online store and data system.
OS	APP application layer customizable development (Android).



Product: milk system cleaner for coffee machine
 Usage: use 1 pill with 500m water (40°C recommended)
 Details: 4g/pill, 120pills/bottle



Product: coffee machine boiler cleaner
 Use: used for coffee machine boiler cleaning
 Ratio: 200g powder with 3.9L water
 Details: 1kg/bottle, 6 bottles/case



Product: coffee machine cleaner
 Use: used for coffee machine brewer cleaning
 Details: 2g/pill, 100 pills/can



Product: cleaning brush
 Use: used for coffee machine cleaning and maintenance
 Details : general use



Product: towel
 Use: used for coffee machine cleaning and maintenance
 Details : general use



Security Certification



Food Contact Material

EU 1935/2004
European food test

Europe

LFGB
German



US

GB
GB4806
China

Europe EVA energy consumption level A

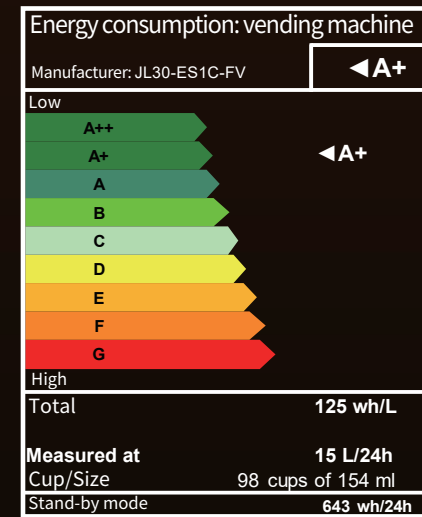

95% Recycled

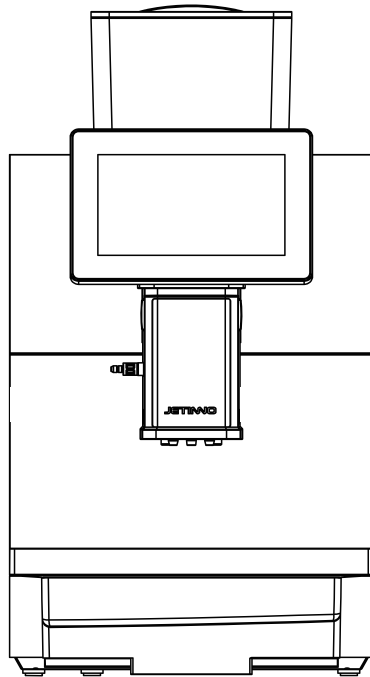

Guangzhou Jetinno Intelligent Equipment Co., Ltd

Address: 4F, No. 2, Ruitai Road, Huangpu District, Guangzhou, China

Tel: 400-017-9997

E-mail: inquiry@jetinno.com

Website: www.jetinnomachine.com www.jetinnovending.com